

# Options

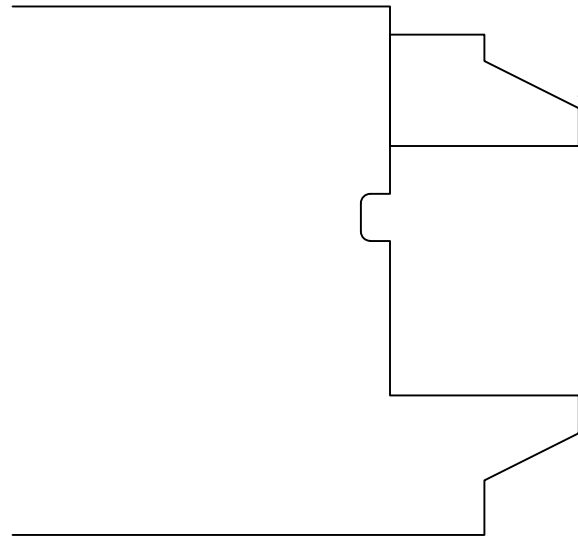

CLASSIC

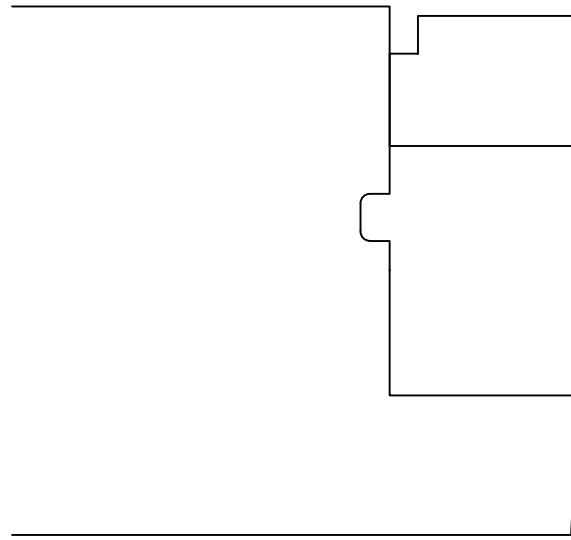

MTN CONTEMPORARY

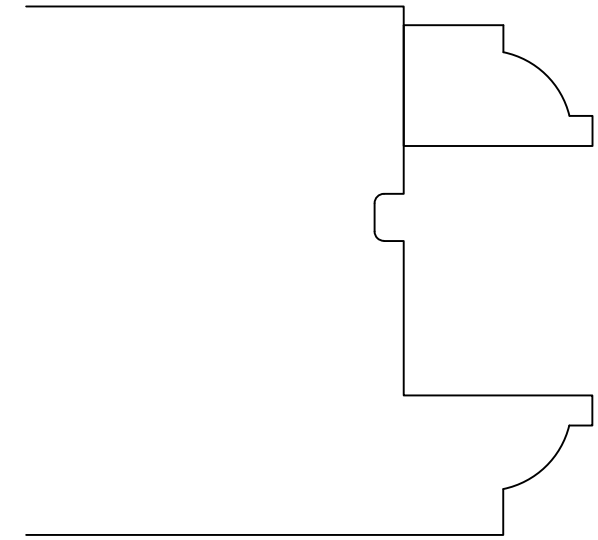

TRADITIONAL

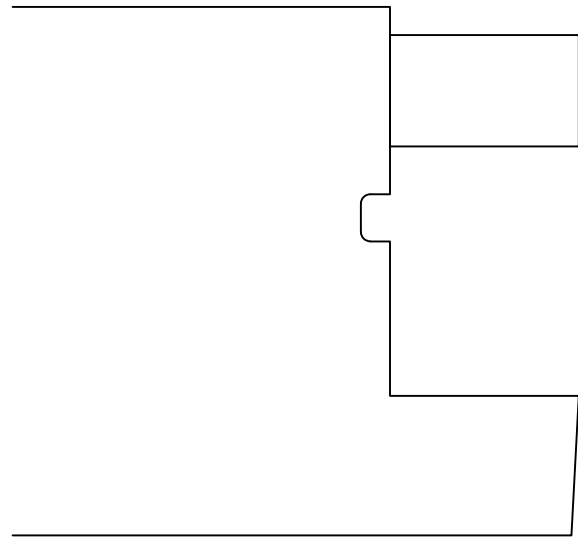

ARTS & CRAFTS

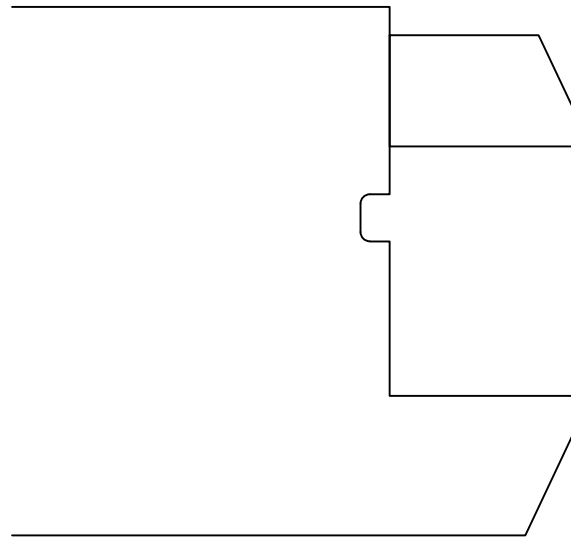

PUTTY

# Options

## SILL DETAIL WITH SILL NOSE

Detail C10: Sill Nose

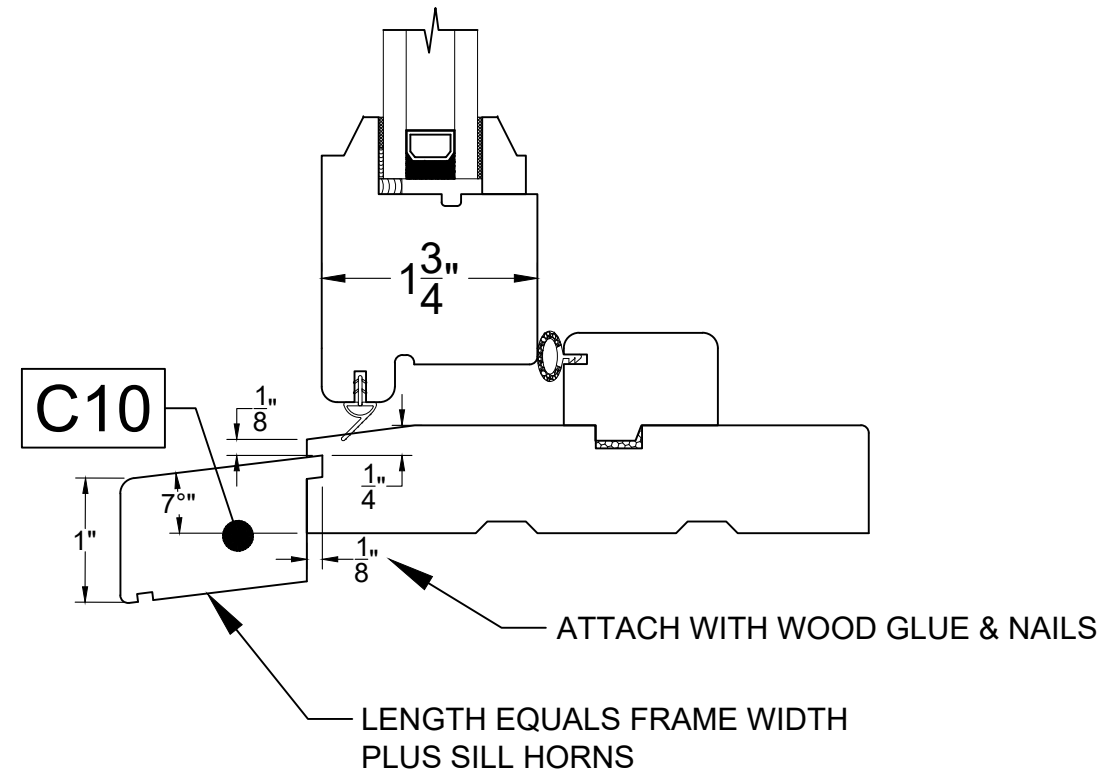
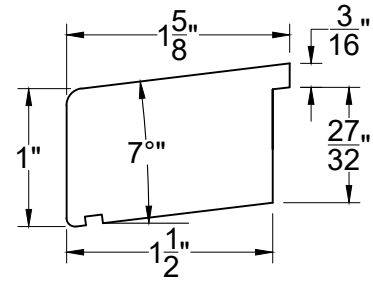

\*\* SILL HORNS OPTIONAL \*\*

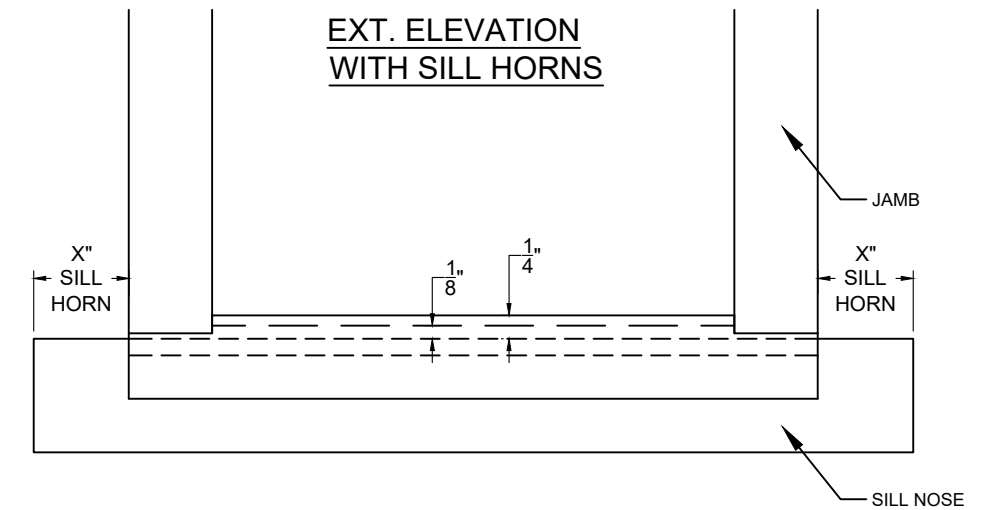
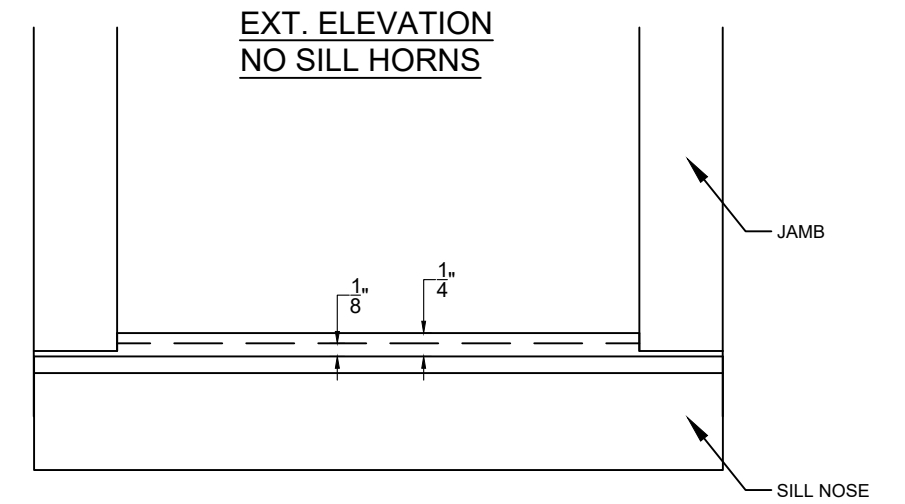

# Options

## Detail C11: Jamb Extension

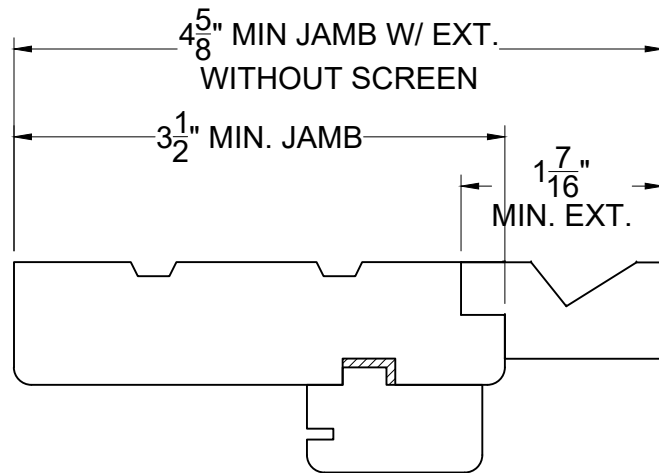
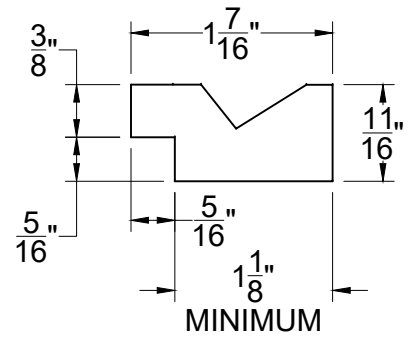
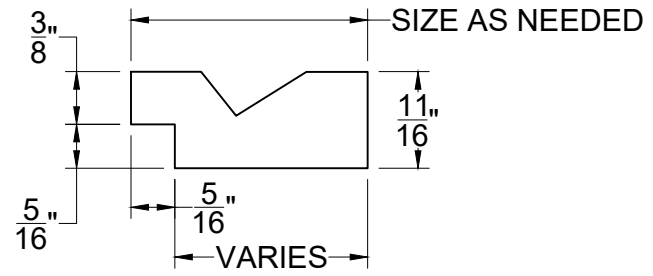

## JAMB EXTENTION TYPICAL AROUND JAMB PERIMETER

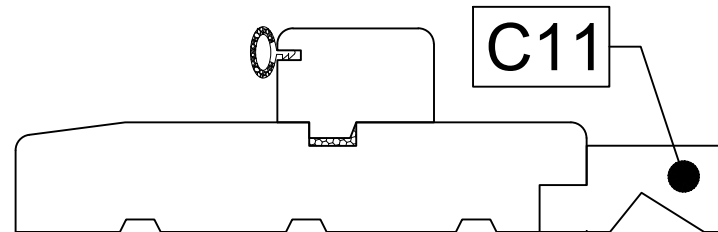
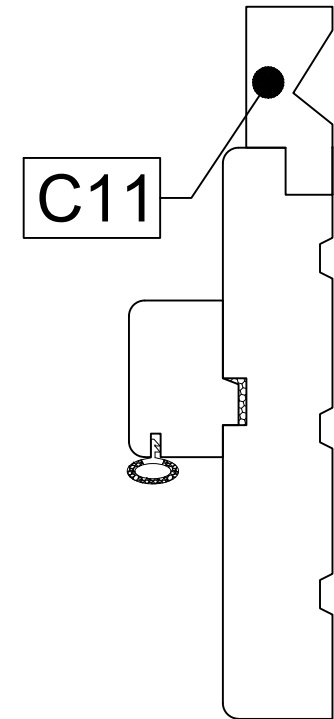
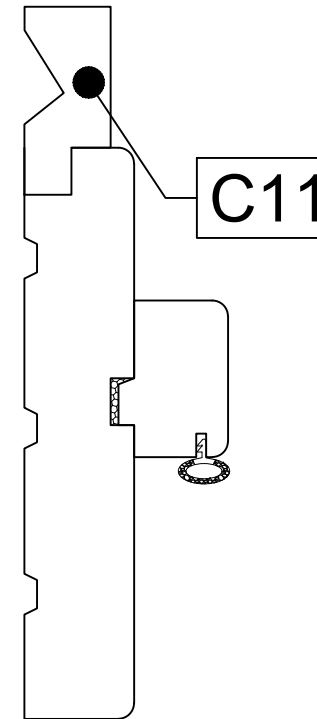
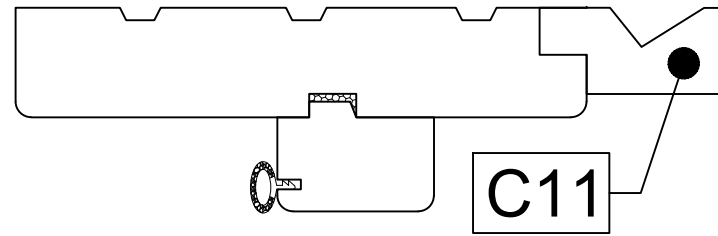

# Options

## Detail: Kerf for Bullnose

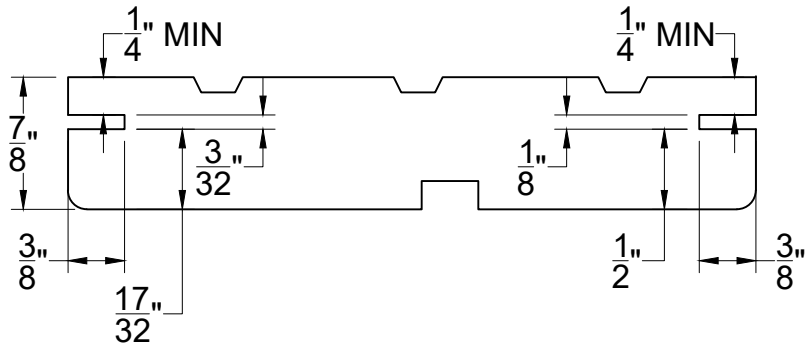

## Customer Option:

- at exterior and / or interior
- around jamb perimeter

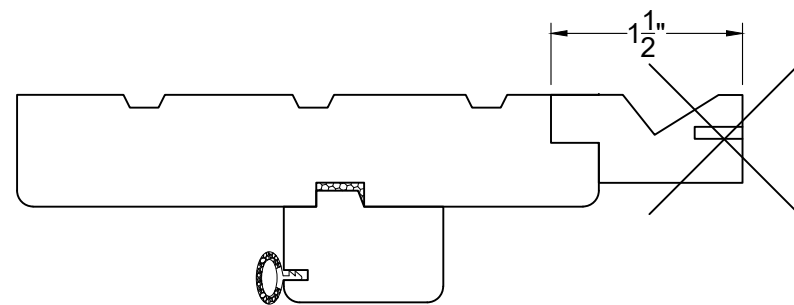
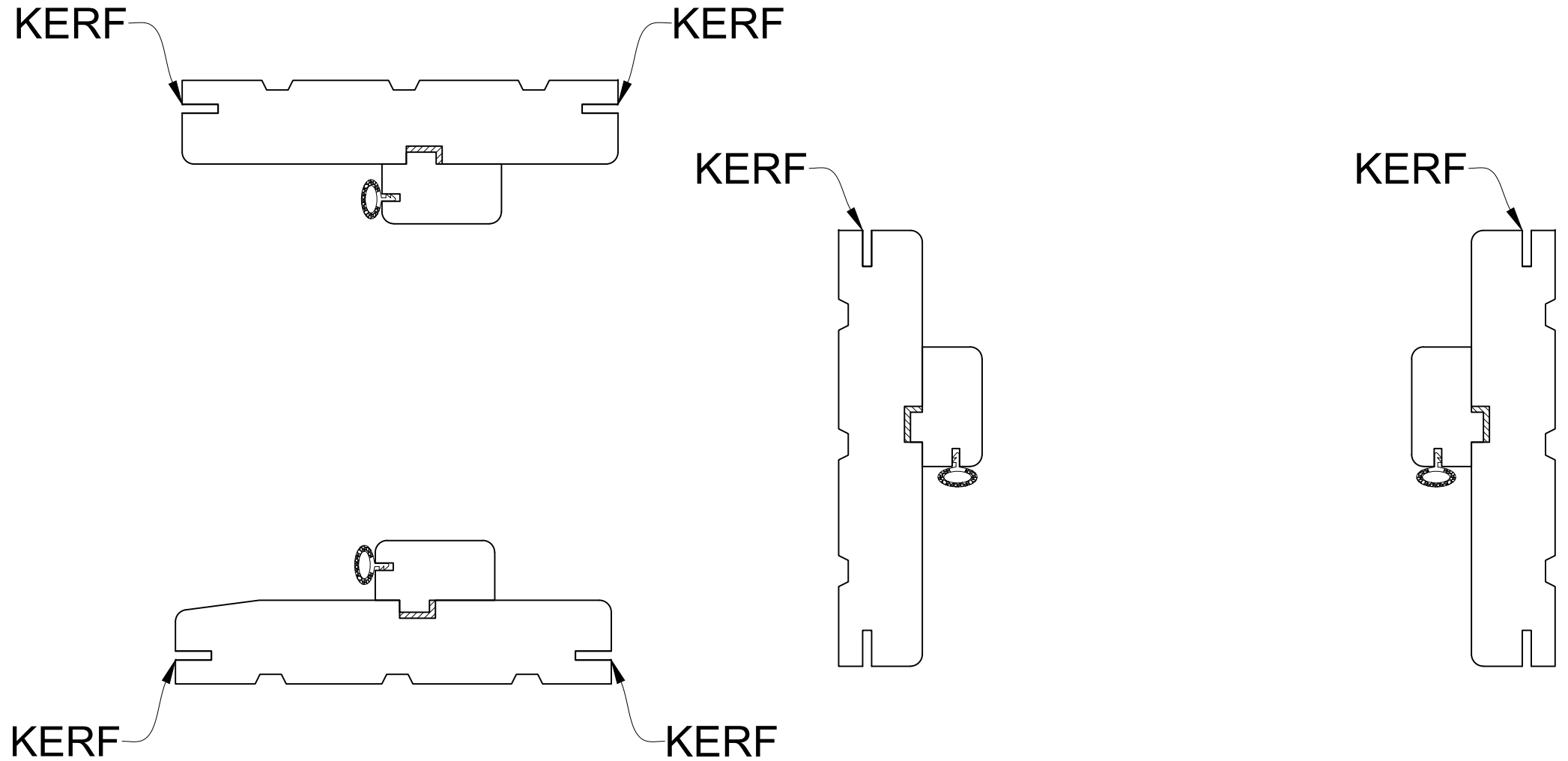

Kerf at interior on extender  
- Not allowed

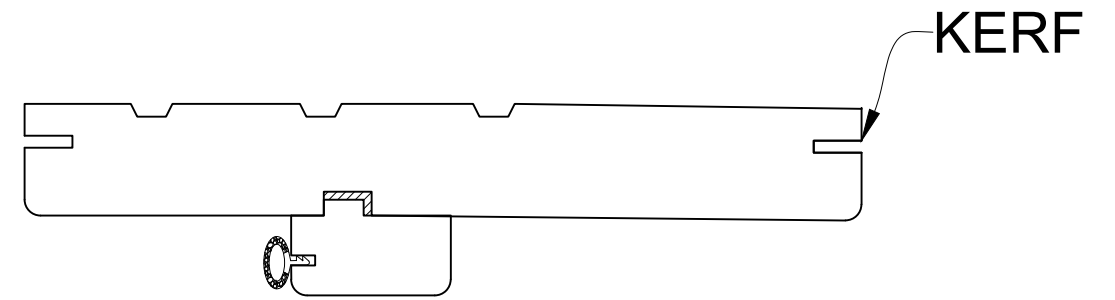

Kerf at interior must be on solid jamb

# Options

## Detail: Plastic Nail Fin

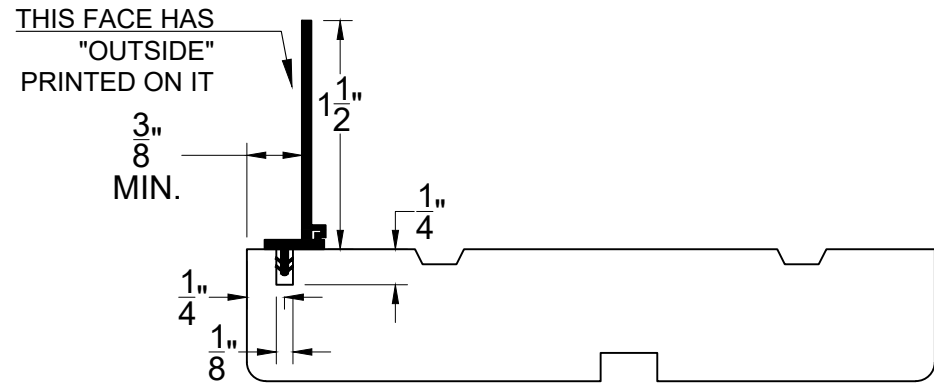

## Alternate location Ship Loose Only

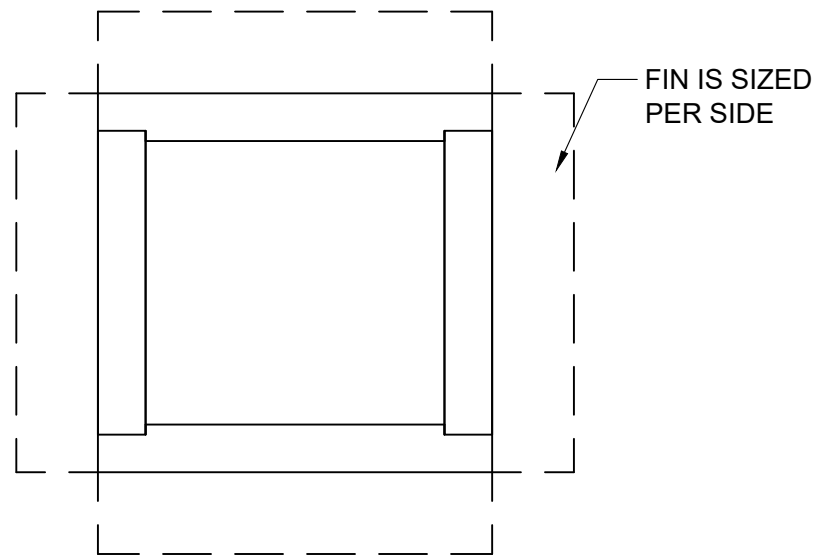
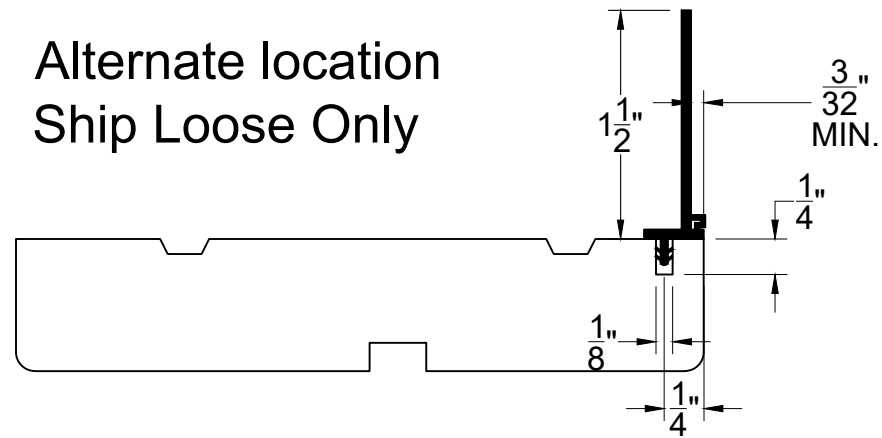

## PLASTIC NAIL FIN TYPICAL AROUND JAMB PERIMETER

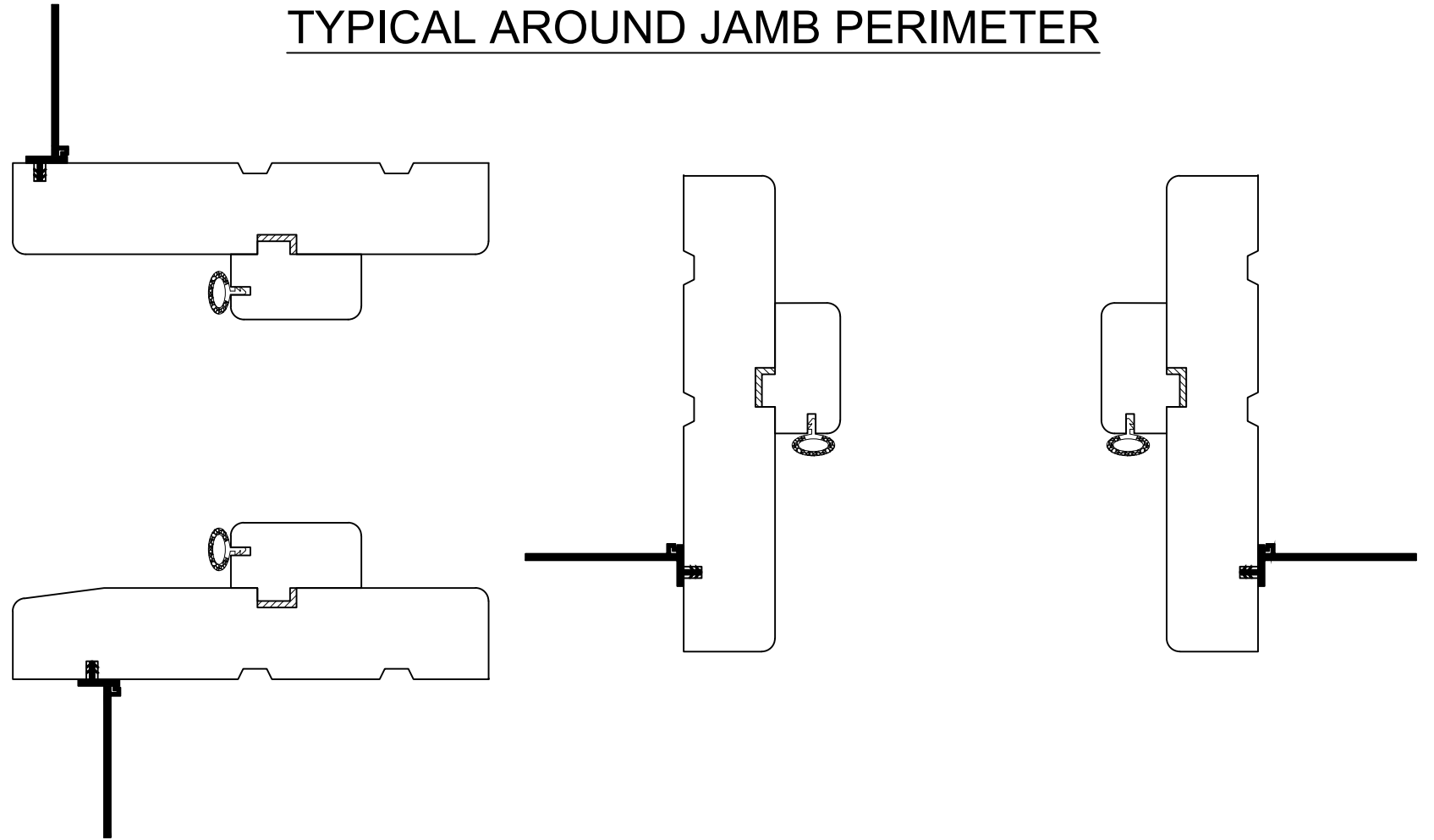

## Typical installation

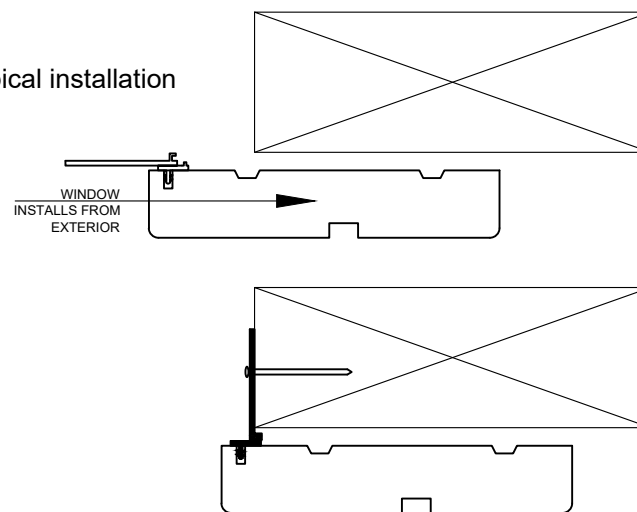

# Options

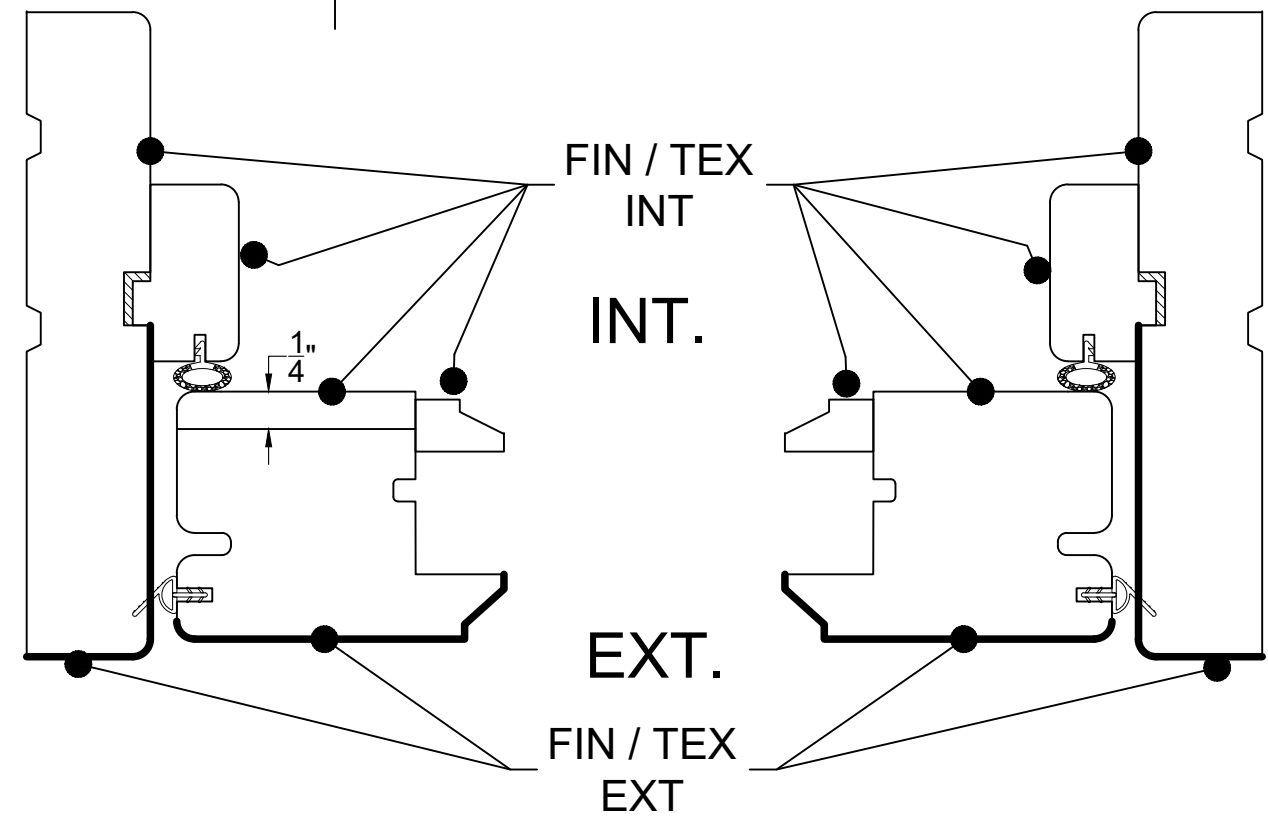
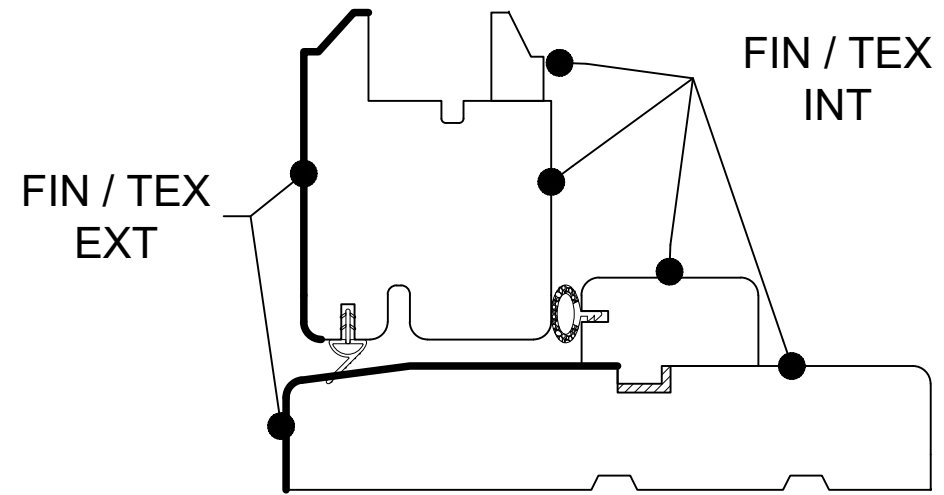
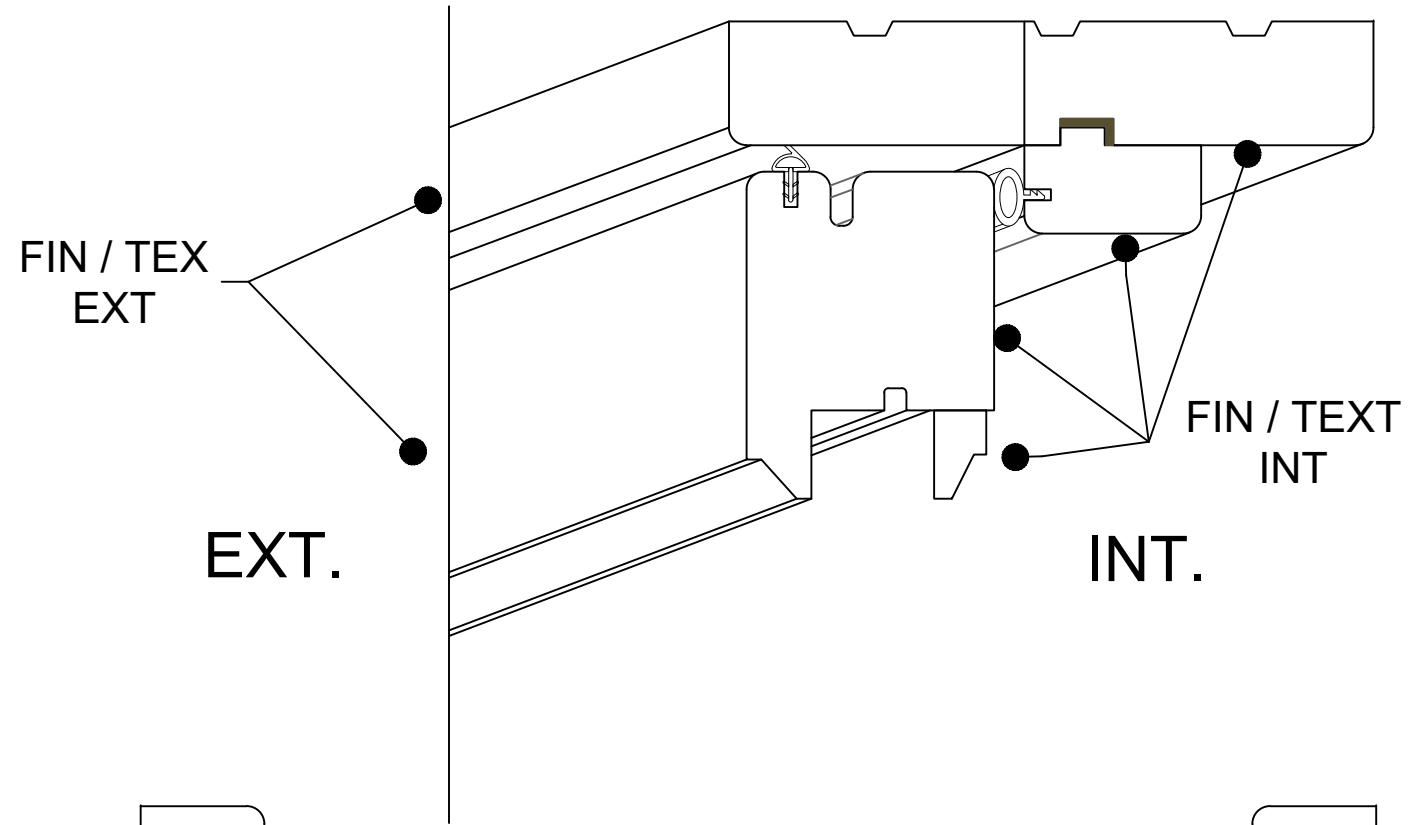
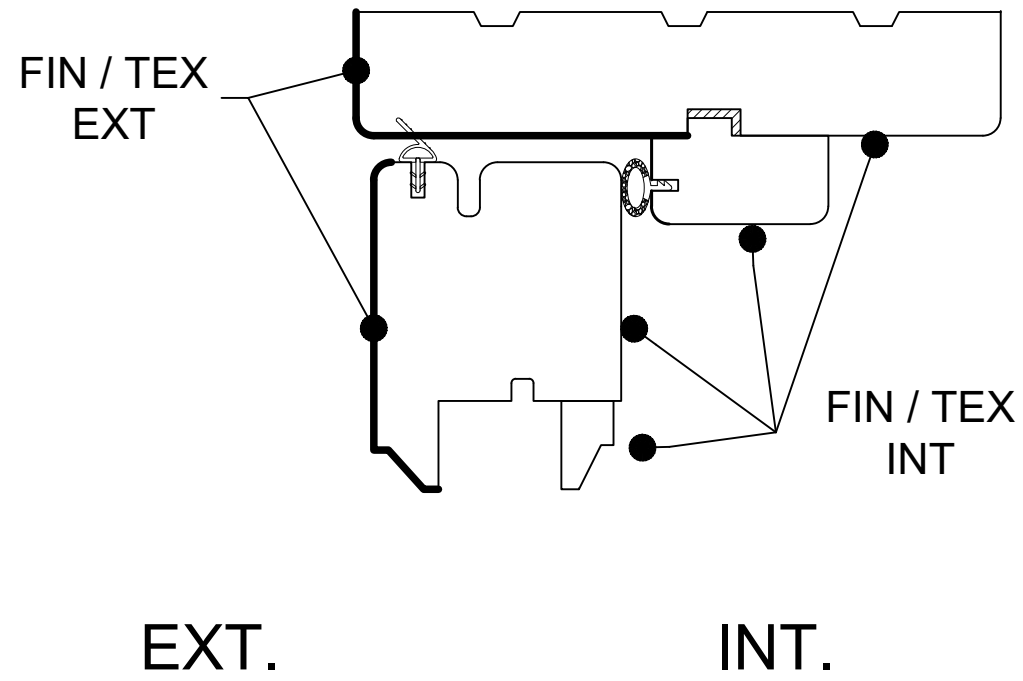

# Options

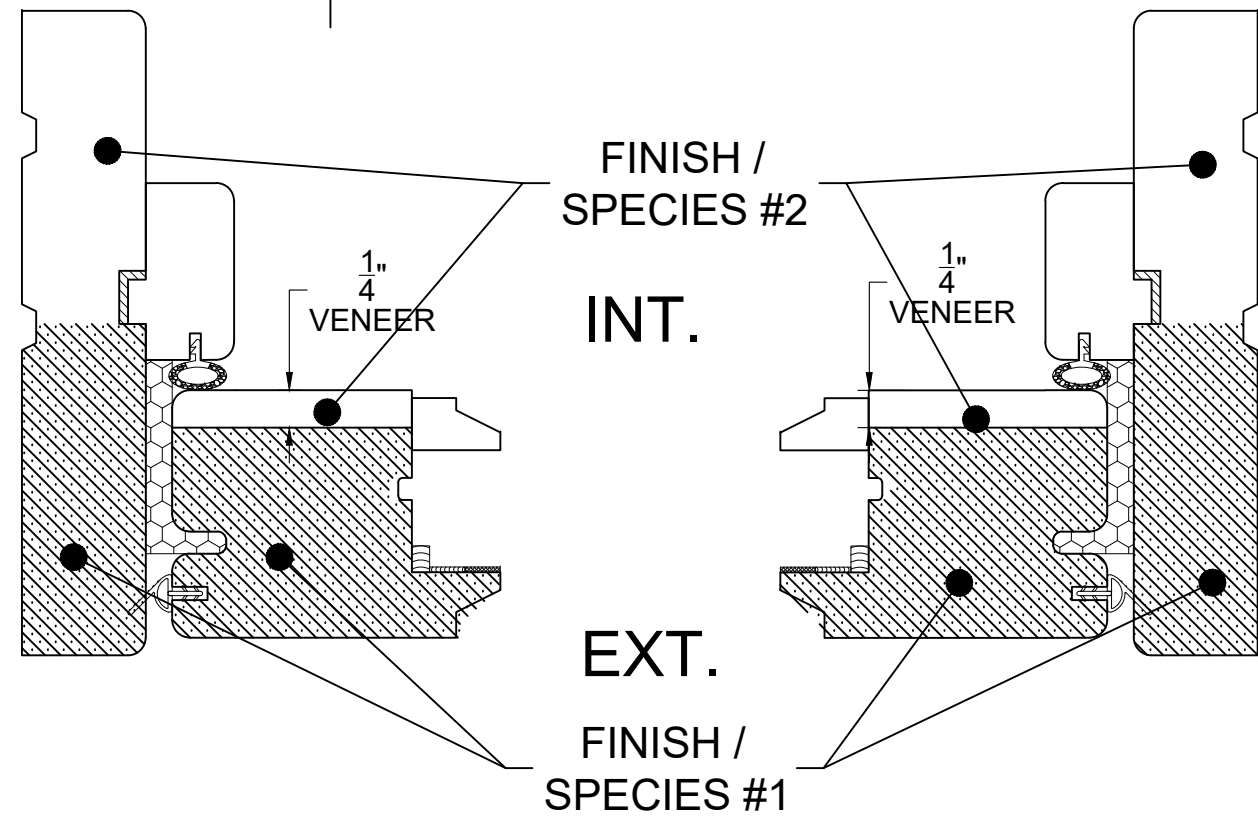
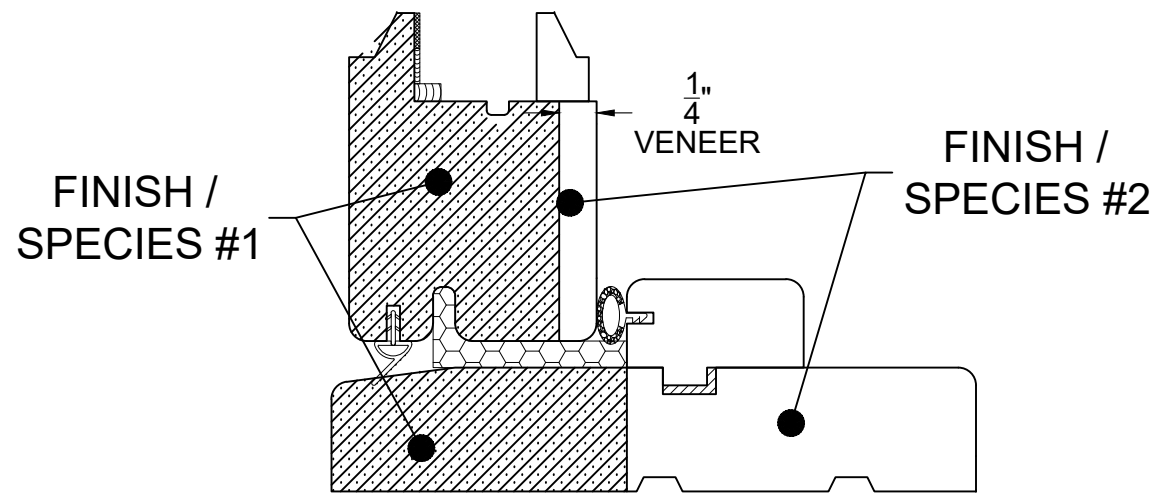
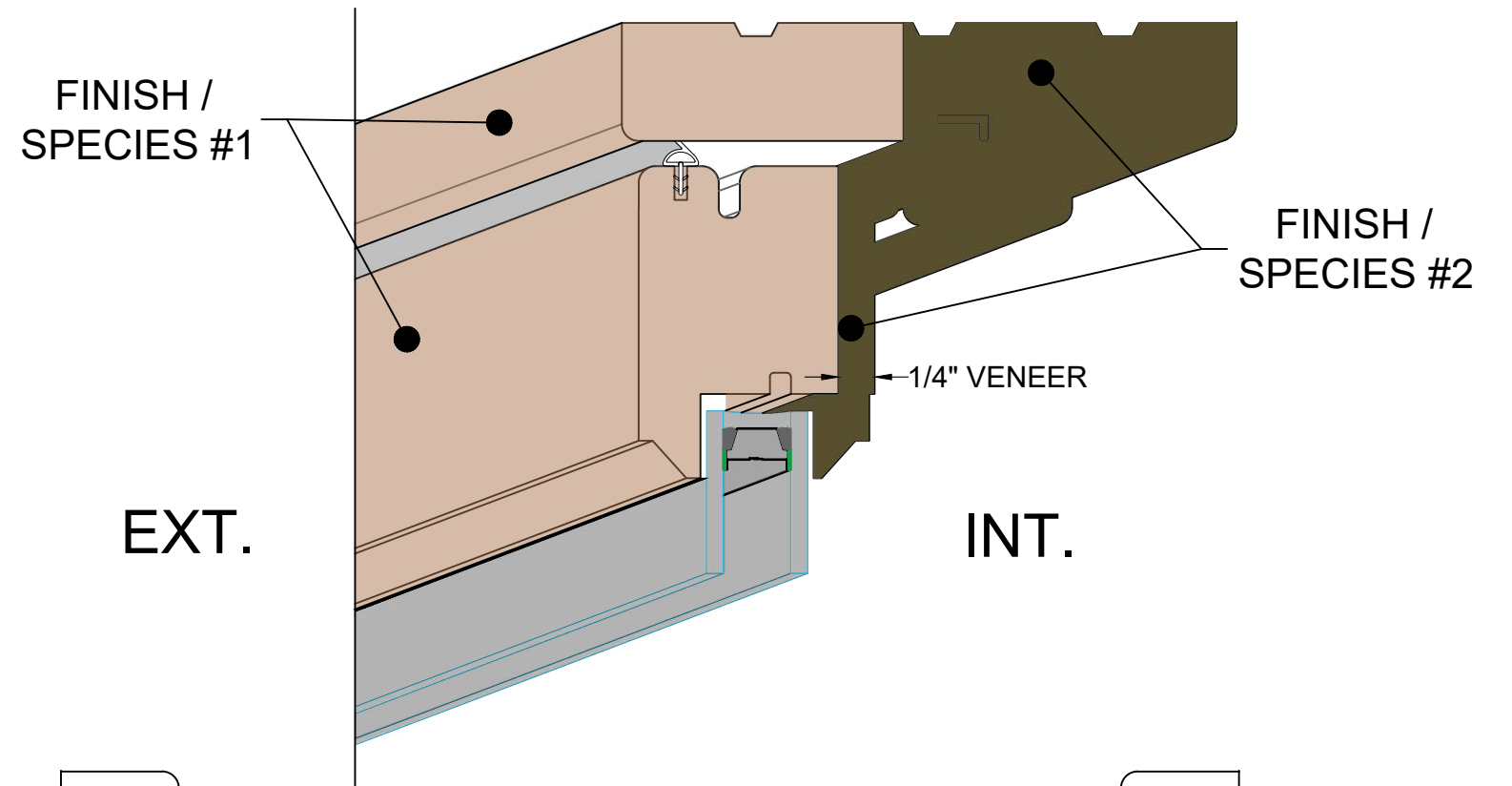
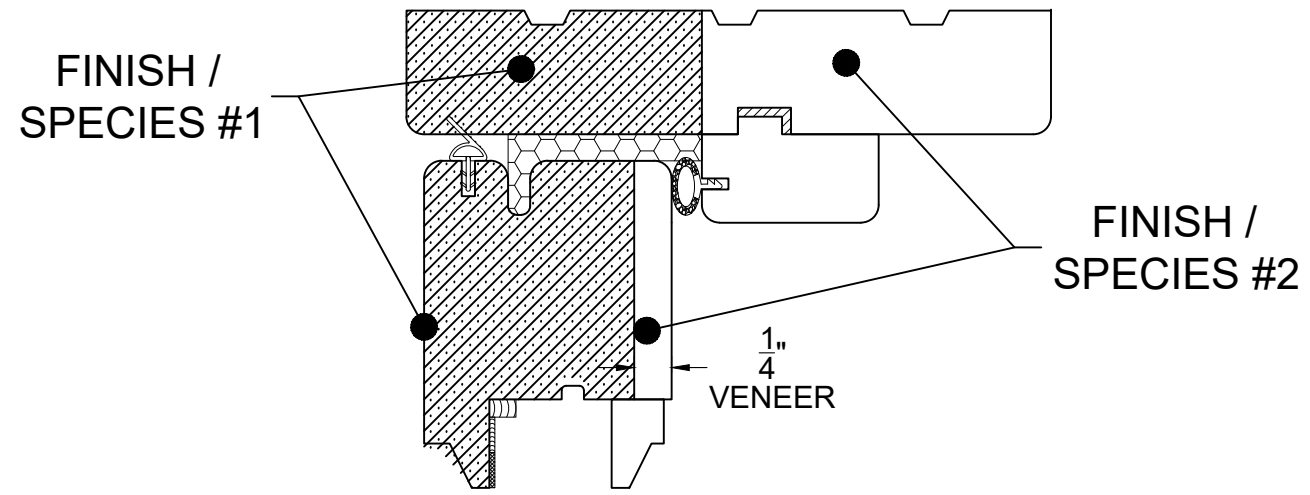

# Options

## WINDOW HARDWARE FINISH BY COMPONENT

LEADING COMPONENT		SASH HINGES	SCREEN HINGES	SCREEN PULL
DESC	FINISH			
MANOR OR ALPINE	SD silicon dark	10B	BK	OA
	BB blackened bronze	10B	BK	FB
	WL white light	15A	SV	SS
NO SASH LOCK		10B	BK	OA
TRADITIONAL CRANK & LOCK	FB faux bronze	10B	BK	OA
	19 brushed nickel	15A	SV	SS
	2 flat black	10B	BK	FB
DOUBLE HUNG LOCKS	BROWN	N/A	BK	OA
HOPPER LATCH	DS	10B	BK	BK



## Options

### FLAT ARCH

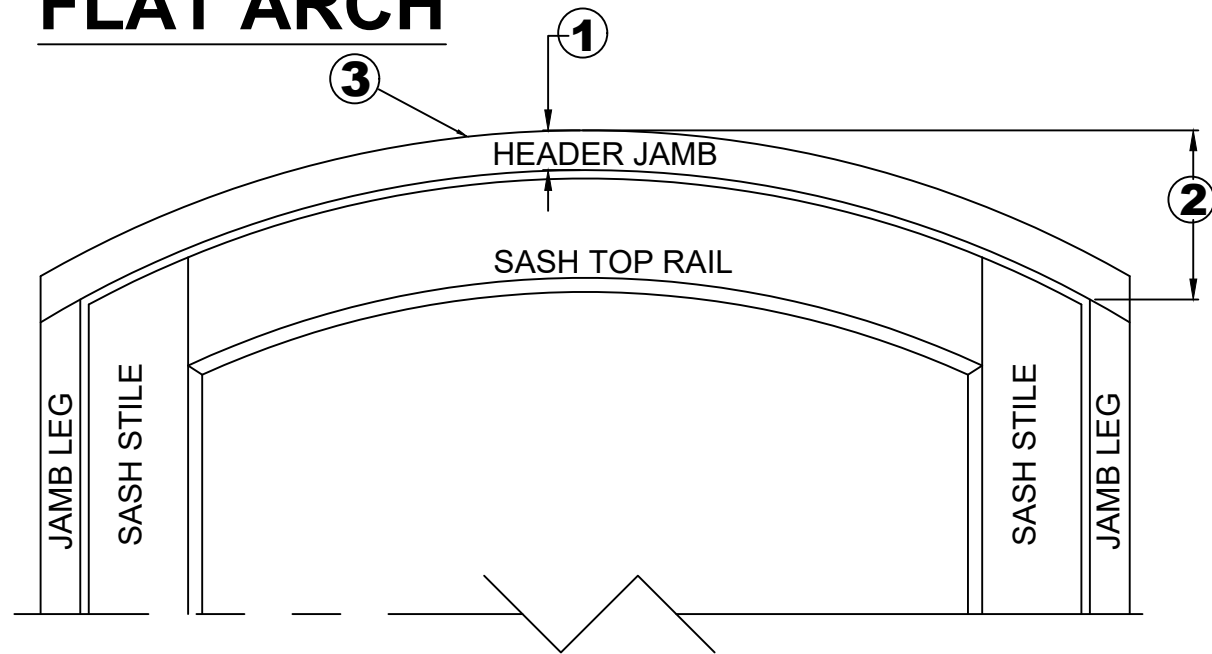

- ① **Width of header jamb at center** - standard width 7/8"
- ② **Width of frame at leg joint or springline of the radius** - depends on window width (this can range from 5" to 10")
- ③ **Outer radius of the header jamb** - equals the window width

### TRUE ARCH

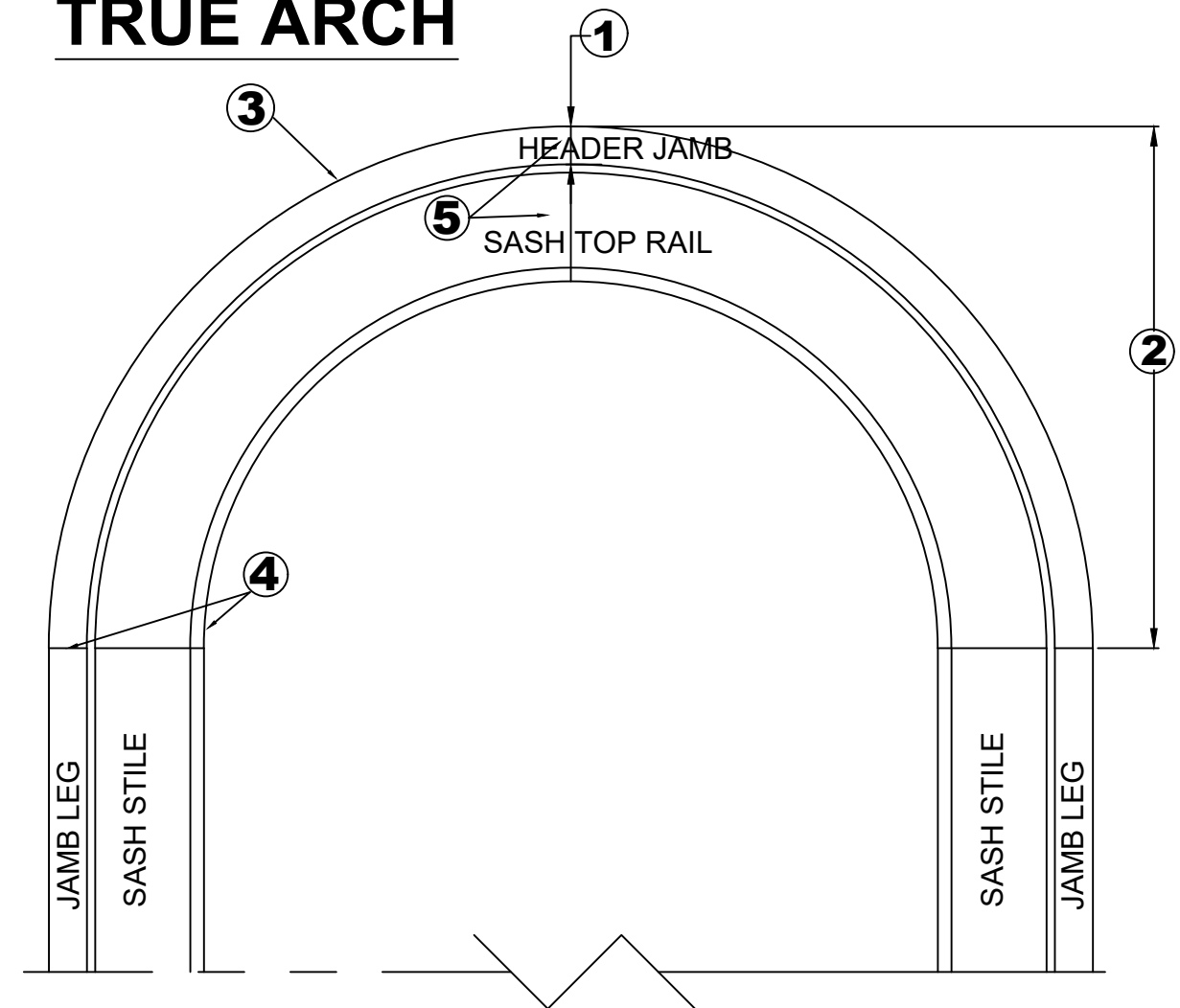

- ① **Width of header at center** - same as stile 7/8"
- ② **Springline** - 1/2 the width of the window
- ③ **Outer radius of the header** - equals 1/2 the width of the door
- ④ **Joint** - assembled with two 3/4"x7" dowels per side, tongue & groove & glue
- ⑤ **Top rail joint** - assembled with 1/2" wood spline & glue

FLAT ARCH OR TRUE ARCH  
LIMITATION FOR HINGED UNITS  
SPRINGLINE  $\geq$  67% OF TOTAL HEIGHT

# Options

## DEFAULT MULL CONDITION

### WINDOW MULLPOST (NO SCREEN)

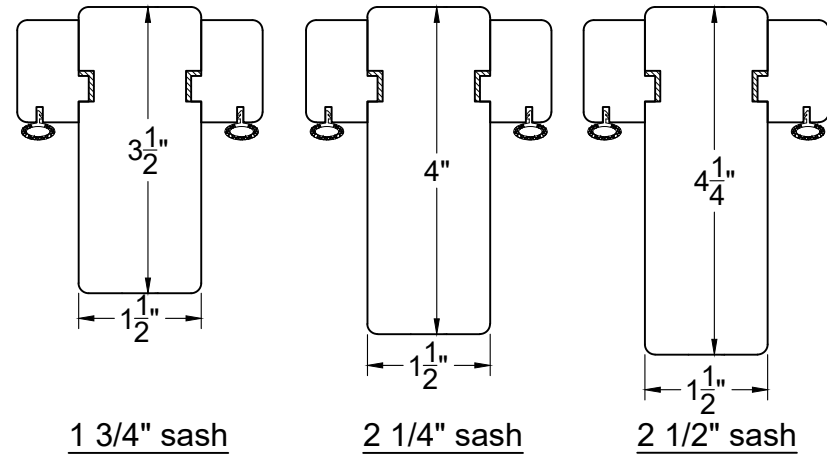

### WINDOW MULLPOST (SCREEN)

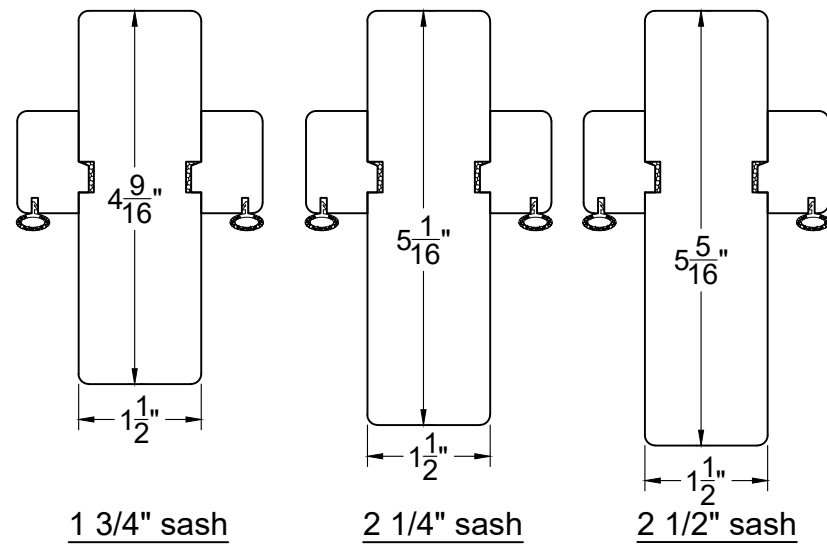

## OPTIONAL FIELD MULL

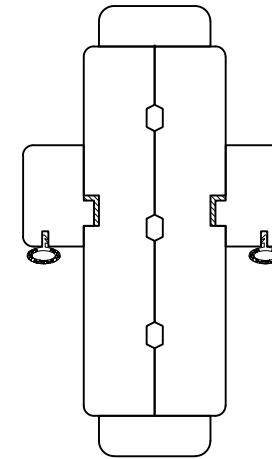

### BACK TO BACK JAMBS WITH MULLCOVERS

## FIELD MULL - DEFAULT MULL COVER

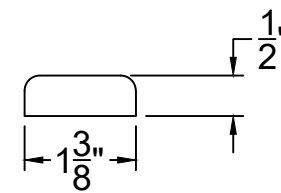

## FIELD MULL - MULL COVERS FOR STACKED/MULLED

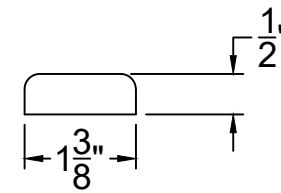

### HORIZONTAL MULL

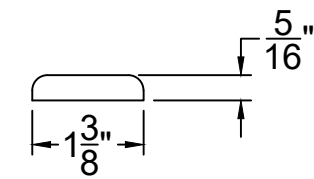

### VERTICAL MULL

# Options

STD JAMB 4 9/16" (NO SCREEN)

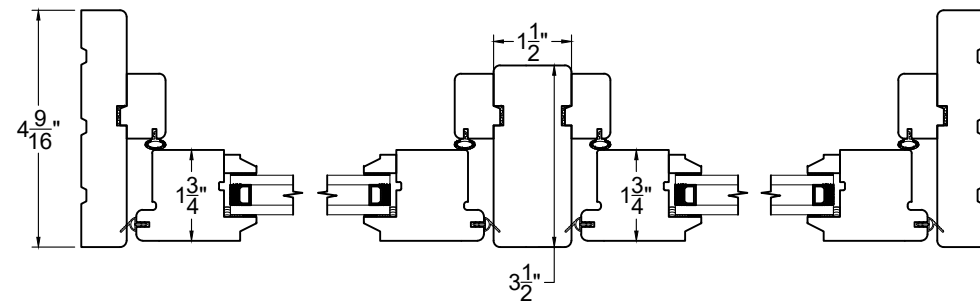

JAMB > 4 9/16" & < 5 11/16" (NO SCREEN)

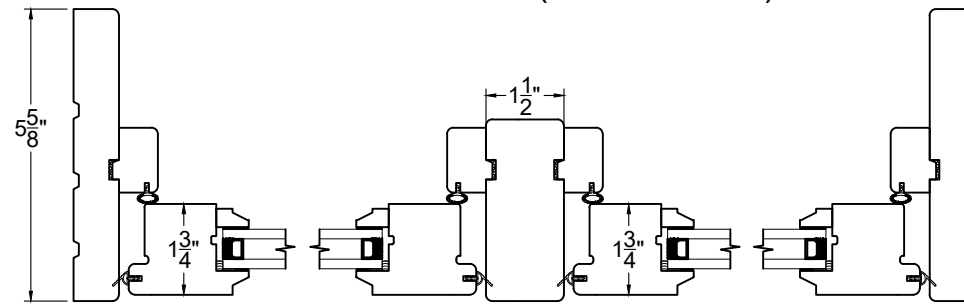

JAMB >= 5 11/16" (NO SCREEN)

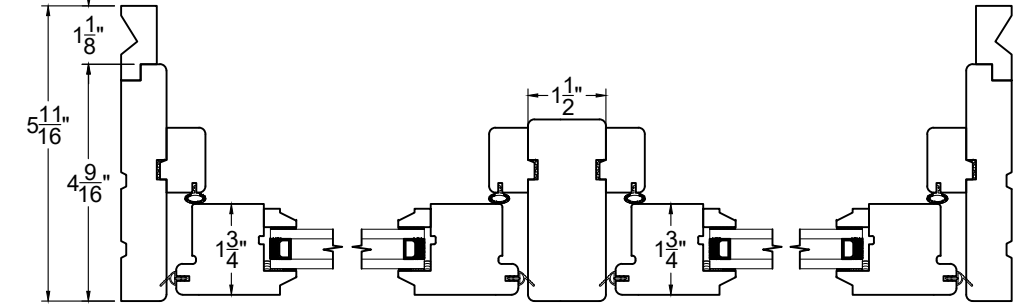

STD JAMB 4 9/16" (WOOD SCREEN)

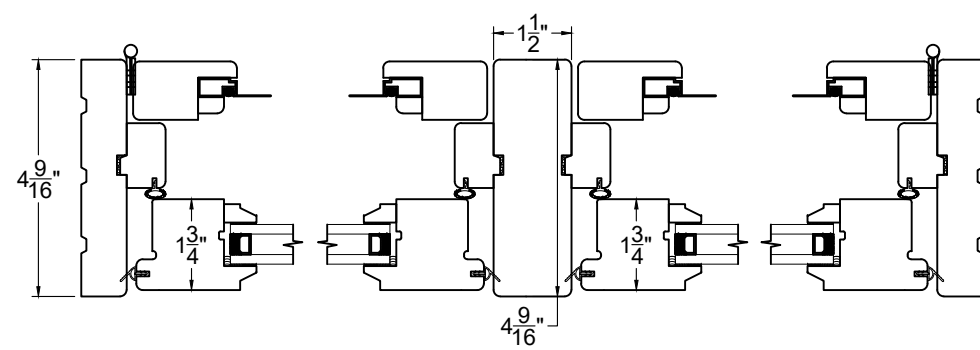

JAMB > 4 9/16" & < 5 11/16" (WOOD SCREEN)

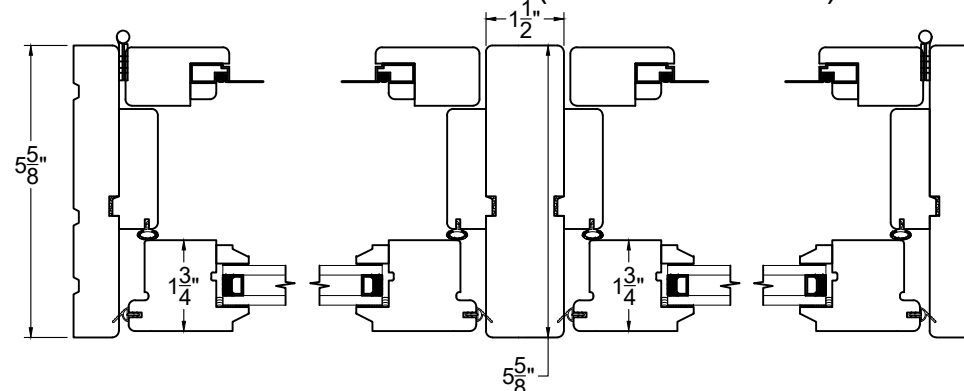

JAMB >= 5 11/16" (WOOD SCREEN)

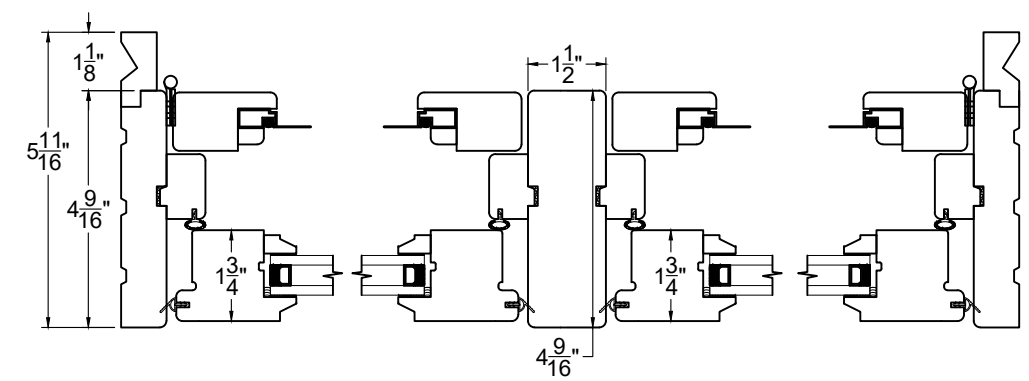

STD JAMB 4 9/16" (ROLL SCREEN)

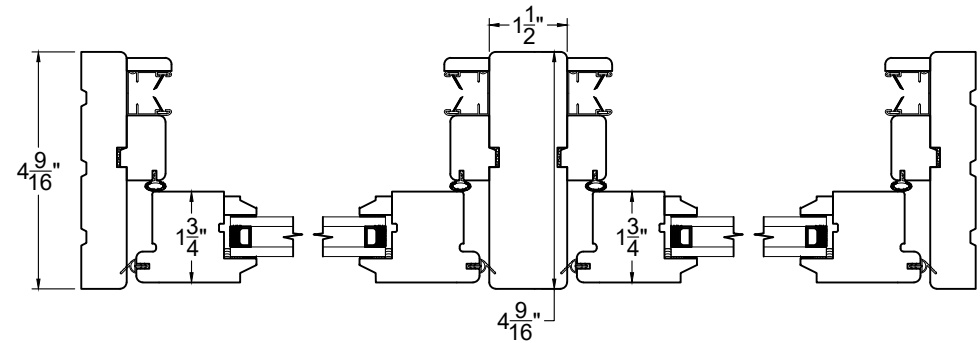

JAMB > 4 9/16" (ROLL SCREEN)

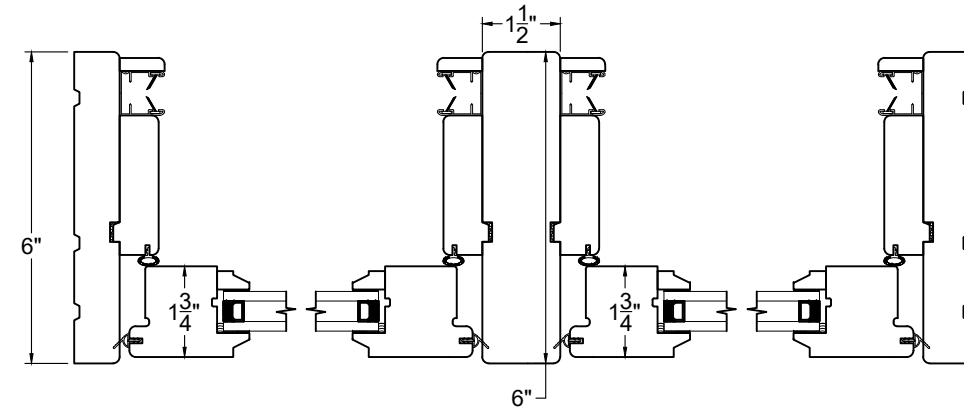

# Options

STD JAMB 4 9/16"  
(NO SCREEN)

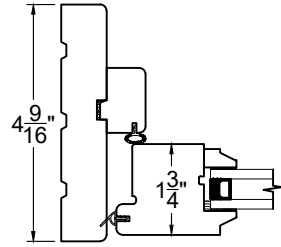

JAMB >4 9/16" & <5 11/16"  
(NO SCREEN)

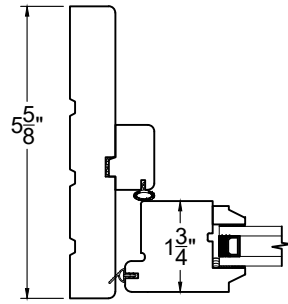

JAMB >= 5 11/16"  
(NO SCREEN)

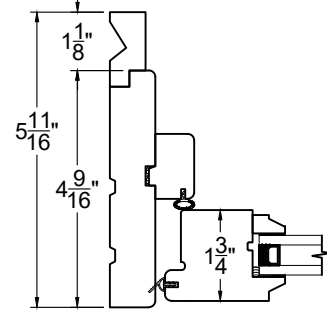

STD JAMB 4 9/16"  
(WOOD SCREEN)

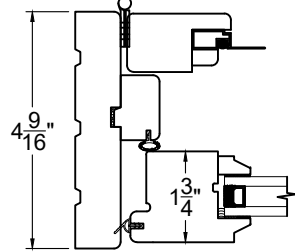

JAMB >4 9/16" & < 5 11/16"  
(WOOD SCREEN)

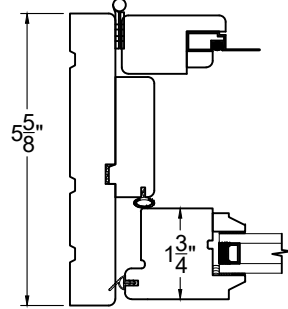

JAMB >= 5 11/16"  
(WOOD SCREEN)

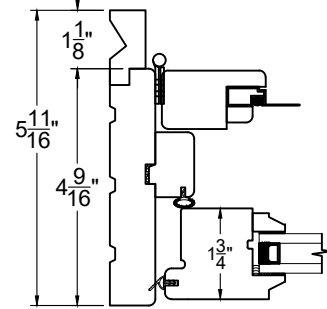

STD JAMB 4 9/16"  
(ROLL SCREEN)

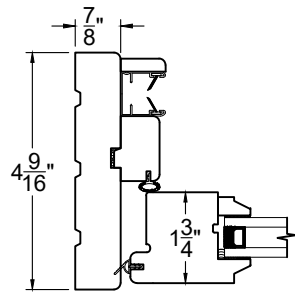

JAMB > 4 9/16"  
(ROLL SCREEN)

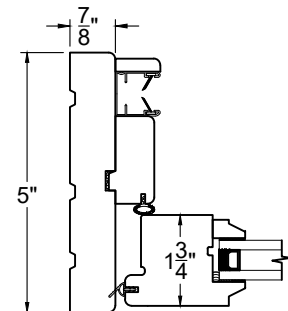

# Options

## GLASS LIMITATIONS - CARDINAL GLASS

TYPE	THICKNESS	MAX STK SHEET
CLEAR	1/8", 3/16", 1/4", 5/16"	94" X 142"
LOW-E (180, 270, 366)	1/8", 3/16", 1/4", 5/16"	94" X 142"
LOW-E (i89)	1/8", 3/16", 1/4"	82" X 142"
TINT (GRY, BRZ)	1/8", 3/16", 1/4", 5/16"	94" X 128"
SATIN ETCH	1/8"	70" X 36"
	3/16"	82" X 128"
GLUE CHIP	1/8"	58" X 82"
	3/16"	70" X 94"
RAIN	3/16"	70" X 94"
OBSCURE	1/8"	58" X 82"
	3/16"	70" X 94"
CROSS REED	5/32"	58" X 94"
NARROW REED	5/32"	58" X 94"
SEEDY	TBD	TBD

## INSULATED GLASS LIMITATIONS - CARDINAL GLASS

PANES THICKNESS	ANNEALED		TEMPERED		LBS/SQFT
	MAX LENGTH	MAX SQFT	MAX LENGTH	MAX SQFT	
1/8"	80"	15	80"	20	3.1
3/16"	100"	33	100"	50	4.9
1/4'	120"	50	142"	60	5.9
5/16"	142"	72	142"	96	8.3